

# HAMILTON-C1

## Technical specification for SW version 3.0.x

### Ventilation modes

Standard: ✓ Option: O Not applicable: --

Mode form	Mode name	Mode	Adult/Ped	Neonatal
Volume-targeted modes, adaptive pressure controlled	APVcmv / (S)CMV+	Breaths are volume targeted and mandatory.	✓	✓
	APVsimv / SIMV+	Volume-targeted mandatory breaths can be alternated with pressure-supported spontaneous breaths.	✓	✓
Pressure-controlled modes	PCV+	All breaths, whether triggered by the patient or the ventilator, are pressure-controlled and mandatory.	✓	✓
	PSIMV+	Mandatory breaths are pressure controlled. Mandatory breaths can be alternated with pressure-supported spontaneous breaths.	✓	✓
	DuoPAP	Mandatory breaths are pressure controlled. Spontaneous breaths can be triggered at both pressure levels.	O	O
	APRV	Spontaneous breaths can be continuously triggered. The pressure release between the levels contributes to ventilation.	O	O
	SPONT	Every breath is spontaneous, with or without pressure-supported s pontaneous breaths.	✓	✓
Intelligent ventilation	ASV	Operator sets %MinVol, PEEP, and Oxygen. Frequency, tidal volume, pressure, and I:E ratio are based on physiological input from the patient.	✓	--
Noninvasive modes	NIV	Every breath is spontaneous.	O	O
	NIV-ST	Every breath is spontaneous as long as the patient is breathing above the set Rate. A backup Rate can be set for mandatory breaths.	O	O
	nCPAP	Demand flow nasal continuous positive airway pressure.	--	O
	nCPAP-PC	Breaths are pressure controlled and mandatory.	--	O

## Standard configuration and options (in alphabetical order)

Standard: ✓ Option: O Not applicable: --

Functions	Adult/Ped	Neonatal
Capnography, mainstream (volumetric) and sidestream	O	O
Communication board:	O	O
CO2/Nurse Call/COM1, CO2/SpO2/COM1 <sup>1</sup> , CO2/SpO2/Humidifier & COM1 <sup>1,2</sup>		
Communication protocols. For details, see the <i>Connectivity</i> brochure	O	O
CPR ventilation	✓	✓
Dynamic Lung	✓	--
Event log (up to 10,000 events with date and time stamp)	✓	✓
Flow trigger	✓	✓
Hamilton Connect Module (connectivity)	O	O
HAMILTON-H900 humidifier integration	O	O
High flow oxygen therapy (HiFlowO2)	O	O
IntelliTrig (leak compensation)	✓	✓
Languages (English, US English, Chinese, Croatian, Czech, Danish, Dutch, Finnish, French, German, Greek, Hungarian, Indonesian, Italian, Japanese, Korean, Norwegian, Polish, Portuguese, Romanian, Russian, Serbian, Slovak, Spanish, Swedish, Turkish, Ukrainian)	✓	✓
Manual breath/prolonged inspiration	✓	✓
Nebulization, pneumatic	✓	--
O2 enrichment	✓	✓
On-screen help	✓	✓
Patient group HAMILTON-C1 neo	--	✓
Patient group HAMILTON-C1	✓	O
Print screen	✓	✓
RJ-45 Ethernet port <sup>3</sup>	✓	✓
Screen lock	✓	✓
Speak valve compatibility	O	--
SpO2 monitoring	O	O
Standby with timer	✓	✓
Suctioning tool	✓	--
Trends/Loops	O	O
USB port	✓	✓
Vent Status (visual representation of patient's ventilator dependence)	✓	✓

<sup>1</sup> Applies only to devices with serial number > 6000

<sup>2</sup> Only available with the HAMILTON-H900 Y-cable

<sup>3</sup> Only available for use if the Hamilton Connect module is activated.

## Technical performance

Description	Specification
Automatic expiratory base flow	<i>Adult/Ped:</i> Fixed at 3 l/min <i>Neonatal:</i> Fixed at 4 l/min
Inspiratory pressure	0 to 60 cmH <sub>2</sub> O
Maximum limited pressure	60 cmH <sub>2</sub> O
Maximum working pressure	<i>Adult/Ped:</i> 60 cmH <sub>2</sub> O (total inspiratory pressure); ensured through pressure limiting <i>Neonatal:</i> 45 cmH <sub>2</sub> O (limitation depending on frequency)
Maximum inspiratory flow	260 l/min (120 l/min with 100% O <sub>2</sub> )
Means of inspiratory triggering	Flow trigger control
Minimum expiratory time	20% of cycle time; 0.2 to 0.8 seconds
Minute volume capability	Up to 60 l/min
Oxygen mixer accuracy	± (volume fraction of 2.5% + 2.5% of actual reading)
Tidal volume	<i>Adult/Ped:</i> 20 to 2000 ml <i>Neonatal:</i> 2 to 300 ml
Preoperational checks	Leak test, flow sensor/circuit/O <sub>2</sub> sensor calibration, CO <sub>2</sub> sensor zero calibration <sup>4</sup>
Display device	Display of settings, alarms, and monitored data <i>Type:</i> Color TFT <i>Size:</i> 640 x 480 pixels, 8.4 in (214 mm) diagonal
Brightness setting for display	The range is 10% to 100% brightness. By default, Day = 80%; Night = 40%.
Alarm volume (loudness) <sup>5</sup>	The range is 1 to 10. The default setting is 5.
Sound power level <sup>6</sup>	51 dB(A) ± 3dB(A)
Sound pressure level <sup>6</sup>	43 dB(A) ± 3dB(A)

## Standards and approvals

Classification	Class IIb, continuously operating according to EC directive 93/42/EEC
Valid versions	IEC 60601-1:2005/A1:2012, ANSI/AAMI ES60601-1:2005(R)2012, CAN/CSA-C22.2 No. 60601-1:14, IEC 60601-1-2:2014, ISO 80601-2-12:2011 + Cor.:2011, ISO 80601-2-55:2018, EN ISO 5356-1:2015, ISO 80601-2-61:2017, ISO 80601-2-49:2018
Declaration	The HAMILTON-C1 was developed in accordance with pertinent international standards and FDA guidelines. The ventilator is manufactured within an EN ISO 13485 and EN ISO 9001, Council Directive 93/42/EEC, Annex II, Article 3 certified quality management system. The ventilator meets the Essential Requirements of Council Directive 93/42/EEC, Annex I.
Electromagnetic compatibility	According to IEC 60601-1-2:2014
Safety class	Class II, Type B applied part (ventilator breathing system, VBS), type BF applied part CO <sub>2</sub> sensor including CO <sub>2</sub> module connector; SpO <sub>2</sub> sensor including adapter, continuous operation according to IEC 60601-1

<sup>4</sup> CO<sub>2</sub> option required.

<sup>5</sup> Volume at 1 meter distance from ventilator. A setting of 1 = 62 dB(A), 5 = 76 dB(A), and 10 = 85 dB(A), with accuracy of ±3 dB(A).

<sup>6</sup> Per ISO 80601-2-12.

## Pneumatic performance

High-pressure oxygen inlet	Pressure:	2.8 to 6 bar / 41 to 87 psi
	Flow:	Maximum of 200 l/min
	Connector:	DISS (CGA 1240) or NIST
Low-pressure oxygen inlet	Pressure:	Maximum 6 bar / 87 psi
	Flow:	≤ 15 l/min
	Connector:	Quick-coupling system, compatible with Colder Products Company (CPC) PMC series
Air supply	Integrated blower	
Gas mixing system	Delivered flow:	<ul style="list-style-type: none"> <li>&gt; 260 l/min ±10% against ambient pressure (at sea level)</li> <li>&gt; 200 l/min with 100% oxygen</li> </ul>
	Delivered pressure:	<i>Adult/Ped:</i> 0 to 60 cmH <sub>2</sub> O <i>Neonatal:</i> 0 to 45 cmH <sub>2</sub> O
	Flow accuracy:	±10% or ±300 ml/min (whichever is greater)
	Inspiratory outlet ( <i>To patient port</i> )	Connector:
Expiratory outlet ( <i>From patient port</i> )	Connector (on expiratory valve):	ISO ID15/OD22 conical

## Electrical specifications

Input power	100 to 240 VAC, 50/60 Hz	
Power consumption	50 VA typical, 150 VA maximum	
Battery	Hamilton Medical provides a high-capacity battery <sup>7</sup> .	
	Electrical specifications:	6.7 Ah, 72 Wh, 50 W typical, 150 W maximum
	Type:	Lithium-ion, supplied by Hamilton Medical only
	Recharge time:	While the ventilator is connected to primary power, approximately 3.25 h to fully recharge one battery.
	Storage:	-20°C to 60°C, ≤ 85% relative humidity. The storage location should be free from vibration, dust, direct sunlight, moisture, and corrosive gases, and with a recommended temperature range < 21°C.  Extended exposure to temperatures above 45°C can degrade battery performance and life.
	Normal operating time:	<p>Operating times are measured with one fully charged battery, the blower in use, without communication board, and with the following settings: Mode = PCV+, Rate = 10 b/min, ΔPcontrol = 10 cmH<sub>2</sub>O, I:E = 1:4, PEEP = 5 cmH<sub>2</sub>O, Flow trigger = 5 l/min, FiO<sub>2</sub> = 40%.</p> <p>Approximate operating times under these conditions are as follows:</p> <ul style="list-style-type: none"> <li>One battery, display brightness = 80%: 4 h</li> <li>One battery, display brightness = 20%: 4.5 h</li> </ul> <p>This operating time applies to new, fully charged Li-ion batteries that have not been exposed to extreme temperatures. The actual operating time depends on battery age and on how the battery is used and recharged.</p>

<sup>7</sup> PN 369108, revision 4 and later.

## Graphical patient data

Graphic type/tab name	Options
Waveforms	Pressure, Volume, Flow, PCO <sub>2</sub> <sup>8</sup> , FCO <sub>2</sub> <sup>8</sup> , Plethysmogram <sup>9</sup>
Intelligent panels	Dynamic Lung <sup>10</sup> , Vent Status, ASV Graph <sup>11</sup>
Trends	1-, 6-, 12-, 24-, or 72-h trend data for a selected parameter or combination of parameters
Loops	Pressure/Volume, Pressure/Flow, Volume/Flow, Volume/PCO <sub>2</sub> <sup>8</sup> , Volume/FCO <sub>2</sub> <sup>8</sup>

## Alarms

Priority	Alarm
High priority	Apnea, Apnea time, ExpMinVol high/low, Oxygen high/low, Minute volume high/low, Pressure high/low, High Pressure during Sigh, Pressure not released Flow sensor calibration needed (during ventilation), Check flow sensor tubing, Check flow sensor, Check patient interface, External flow sensor failed, Replace O <sub>2</sub> sensor, Oxygen supply failed, Buzzer defective, Loudspeaker defective Disconnection on patient/ventilator side, Exhalation obstructed, Obstruction Options not found, Self test failed, Blower fault, Device temperature high, Vent outlet temperature high Battery low, Battery power loss, Battery totally discharged, Battery temperature high, Battery communication error, Battery defective SpO <sub>2</sub> : <sup>12</sup> SpO <sub>2</sub> low
Medium priority	High Flow, fTotal high/low, Frequency high/low, Vt high/low, Inspiratory volume limitation, High PEEP, Loss of PEEP, Pressure limitation Wrong expiratory valve, Circuit calibration needed, Flow sensor calibration needed, Flip the flow sensor, Check flow sensor for water (Neonatal) Check for blockage, Fan failure, Function key not operational, Performance limited by high altitude, Real-time clock failure, Battery low CO <sub>2</sub> : <sup>13</sup> PetCO <sub>2</sub> high/low SpO <sub>2</sub> : <sup>12</sup> SpO <sub>2</sub> : Adapter missing, SpO <sub>2</sub> : Light interference, SpO <sub>2</sub> : Low perfusion index, SpO <sub>2</sub> : Poor signal, SpO <sub>2</sub> : Probe missing, SpO <sub>2</sub> : Patient disconnected, SpO <sub>2</sub> : Sensor error, PI low/high, PVI low/high, Pulse low/high, SpO <sub>2</sub> low
Low priority	Check Plimit, ASV: Cannot meet the target, Maximum leak compensation, Pressure limit has changed, CPR ON, SpeakValve ON/OFF, Suctioning maneuver, Apnea ventilation/Apnea ventilation ended Flow sensor calibration needed, Preventive maintenance required, Replace HEPA filter, Blower service required, Loss of external power, IRV (inverse ratio ventilation), Release valve defective, Touch not functional, Check settings Battery calibration required, Battery replacement required, Wrong battery, Battery low O <sub>2</sub> sensor calibration needed, O <sub>2</sub> sensor defective, O <sub>2</sub> sensor missing, O <sub>2</sub> sensor not system compatible External connections disabled <sup>14</sup> , JTAG not working, Invalid communication board CO <sub>2</sub> : <sup>13</sup> CO <sub>2</sub> calibration needed, CO <sub>2</sub> sensor defect, CO <sub>2</sub> sensor disconnected, CO <sub>2</sub> sensor over temperature, CO <sub>2</sub> sensor warmup, Check CO <sub>2</sub> sampling line, Check CO <sub>2</sub> airway adapter, CO <sub>2</sub> : Poor signal SpO <sub>2</sub> : <sup>12</sup> SpO <sub>2</sub> high

<sup>8</sup> CO<sub>2</sub> option required.

<sup>9</sup> SpO<sub>2</sub> option required.

<sup>10</sup> Only for adult/pediatric patients.

<sup>11</sup> Only in ASV mode.

<sup>12</sup> If the SpO<sub>2</sub> option is installed and enabled.

<sup>13</sup> If the CO<sub>2</sub> option is installed and enabled.

<sup>14</sup> If the Hamilton Connect module is installed and enabled.

## Control settings and ranges

Parameter (units)	Range Adult/Ped <sup>15</sup>	Range Neonatal <sup>15</sup>
%MinVol (%) <sup>16</sup>	25 to 350	--
Apnea backup	On, Off	On, Off
ETS (%)	5 to 80	5 to 80
Flow (l/min) <sup>17</sup>	2 to 60	2 to 15
I:E <sup>18</sup>	1:9 to 4:1	1:9 to 4:1
IBW (kg) (calculated)	3 to 139	--
Oxygen (%)	21 to 100	21 to 100
P high (cmH <sub>2</sub> O) (in APRV)	0 to 60	0 to 45
P high (cmH <sub>2</sub> O) (in DuoPAP)	0 to 60	3 to 45
P low (cmH <sub>2</sub> O) (in APRV)	0 to 35	0 to 25
Pat. height		
(cm)	30 to 250	--
(in)	12 to 98	
PEEP/CPAP (cmH <sub>2</sub> O)	0 to 35	3 to 25
Plimit (cmH <sub>2</sub> O)	5 to 60	5 to 60
P-ramp (ms) <sup>19</sup>	0 to 2000 ASV, NIV, NIV-ST, SPONT, VS: max = 200	0 to 600 NIV, NIV-ST, SPONT, nCPAP-PC, VS: max = 200
Rate (b/min) <sup>20</sup>	1 to 80 APVcmv, PCV+: 4 to 80 PSIMV+, NIV-ST: 5 to 80	1 to 80 PSIMV+: 5 to 80 APVcmv, PCV+, PSIMV+PSync, nCPAP-PC, NIV-ST, APVsimv + Apnea backup: 10 to 80
Set temp (°C)	INV: 35 to 41 NIV: 30 to 35 HiFlowO <sub>2</sub> : 33 to 37	INV: 35 to 41 NIV: 30 to 35 HiFlowO <sub>2</sub> : 33 to 37
Sex	Male, Female	--
Sigh	On, Off	--
SpeakValve	On, Off	--
T gradient (°C)	-2 to 3	-2 to 3
T high (s) (in APRV and DuoPAP) <sup>20</sup>	0.1 to 40.0	0.1 to 40.0
T low (s) (in APRV)	0.2 to 40.0	0.2 to 40.0
TI (s) <sup>18,20</sup>	0.1 to 12.0	0.1 to 12.0
TI max (s)	0.5 to 3.0	0.25 to 3.0
Trigger, flow (l/min) <sup>21</sup>	0.5 to 20.0 APVcmv, PCV+: 0.5 to 20.0 / Off	0.1 to 5.0 APVcmv, PCV+: 0.1 to 5.0 / Off
Vt (ml)	20 to 2000	2 to 300
Vt/IBW	5 to 12	5 to 12
Vt/Weight (ml/kg) <sup>22</sup>		
Weight (kg)	--	0.2 to 30.0

<sup>15</sup> Parameter settings and ranges can vary depending on the selected mode.

<sup>16</sup> Only in ASV mode.

<sup>17</sup> Only for high flow oxygen therapy.

<sup>18</sup> In PCV+, (S)CMV, and APVcmv modes, mandatory breath timing can be controlled by using a combination of inspiratory time (TI) and Rate, or by the I:E ratio; set the method in Configuration. All other modes are controlled by using a combination of inspiratory time (TI) and Rate.

<sup>19</sup> P-ramp is limited to one-third (1/3) of TI time. Adjustment of TI time can override the P-ramp setting.

<sup>20</sup> Startup setting derived from IBW (adult/pediatric), body weight setting (neonatal). Does not apply in ASV mode.

<sup>21</sup> Flow trigger is leak compensated.

<sup>22</sup> IBW is calculated using height and sex, for adult and pediatric patients. Actual body weight is used for neonates.

Parameter (units)	Range Adult/Ped <sup>15</sup>	Range Neonatal <sup>15</sup>
$\Delta P_{control}$ (cmH <sub>2</sub> O) <sup>23</sup>	5 to 60	3 to 45 <i>nCPAP-PC</i> : 0 to 45
$\Delta P_{insp}$ (cmH <sub>2</sub> O) <sup>23</sup>	3 to 60	3 to 45
$\Delta P_{support}$ (cmH <sub>2</sub> O) <sup>23</sup>	0 to 60	0 to 45

## Monitoring parameters

Parameter (units)	Description	
Pressure	AutoPEEP (cmH <sub>2</sub> O)	Unintended positive end-expiratory pressure
	PEEP/CPAP (cmH <sub>2</sub> O)	PEEP (positive end-expiratory pressure) and CPAP (continuous positive airway pressure)
	Driving pressure, $\Delta P$ (cmH <sub>2</sub> O)	Driving pressure, calculated value reflecting the difference between $P_{plateau}$ and PEEP
	$\Delta P_{insp}$ (cmH <sub>2</sub> O)	Inspiratory pressure
	$P_{mean}$ (cmH <sub>2</sub> O)	Mean airway pressure
	$P_{peak}$ (cmH <sub>2</sub> O)	Peak airway pressure
	$P_{plateau}$ (cmH <sub>2</sub> O)	Plateau or end-inspiratory pressure
	$P_{prox}$ (cmH <sub>2</sub> O)	Airway pressure at proximal patient interface
Flow	Flow (l/min)	HiFlowO <sub>2</sub> : The set flow of gas to the patient <i>nCPAP</i> : The average flow updated every second <i>nCPAP-PC</i> : The average flow during expiration, updated every breath
	Insp Flow (peak) (l/min)	Peak inspiratory flow, spontaneous or mandatory
	Exp Flow (peak) (l/min)	Peak expiratory flow
	Volume	ExpMinVol or MinVol NIV (l/min)
MVSpont or MVSpont NIV (l/min)		Spontaneous expiratory minute volume
VTE or VTE NIV (ml)		Expiratory tidal volume
VTESpont (ml)		Spontaneous expiratory tidal volume
VTI (ml)		Inspiratory tidal volume
VLeak (%)		Leakage percent or total minute volume leakage
MVLeak (l/min)		Leakage percent or total minute volume leakage
Vt/IBW or Vt/Weight (ml/kg)		Tidal volume is calculated by ideal body weight (adult/pediatric patients) or actual body weight (neonatal patients)
Oxygen	Oxygen (%)	Oxygen concentration of the delivered gas
	O <sub>2</sub> consumption (l/min)	The current oxygen consumption rate
Time	CPR timer	MMP during CPR ventilation showing duration of CPR ventilation
	I:E	Ratio of the patient's inspiratory time to expiratory time for every breath cycle
	fControl (b/min)	Mandatory breath frequency
	fSpont (b/min)	Spontaneous breathing frequency
	fTotal (b/min)	Total breathing frequency
	TI (s)	Inspiratory time
	TE (s)	Expiratory time

<sup>23</sup>  $\Delta P_{control}$ : Control pressure, added to PEEP/CPAP.  $\Delta P_{insp}$ : Inspiratory pressure, added to PEEP/CPAP.  $\Delta P_{support}$ : Pressure support, added to PEEP/CPAP.

Parameter (units)	Description	
Lung mechanics	Cstat (ml/cmH2O)	Static compliance
	P0.1 (cmH2O)	Airway occlusion pressure
	PTP (cmH2O*s)	Pressure time product
	RCexp (s)	Expiratory time constant
	Rinsp (cmH2O / (l/s))	Inspiratory flow resistance
	RSB (1 / (l*min))	Rapid shallow breathing index
CO2	FetCO2 (%)	Fractional end-tidal CO2 concentration
	PetCO2 (mmHg)	End-tidal CO2 pressure
	slopeCO2 (%CO2/l)	Slope of the alveolar plateau in the PetCO2 curve, indicating the volume/flow status of the lungs
	V'alv (l/min)	Alveolar minute ventilation
	Vtalv (ml)	Alveolar tidal ventilation
	V'CO2 (ml/min)	CO2 elimination
	VDaw (ml)	Airway dead space
	VDaw/VTE (%)	Airway dead space fraction at the airway opening
	VeCO2 (ml)	Exhaled CO2 volume
	ViCO2 (ml)	Inspired CO2 volume
SpO2	SpO2 (%)	Oxygen saturation
	Pulse (1/min)	Pulse
	SpO2/FiO2 (%)	The SpO2/FiO2 ratio (%) is an approximation of the PaO2/FiO2 ratio, which, in contrast to PaO2/FiO2, can be calculated noninvasively and continuously
	OSI	Oxygen saturation index
	PI (%)	Perfusion index
	PVI (%)	Pleth variability index
Humidifier <sup>24</sup>	T Y-piece (°C)	Measured temperature at the Y-piece
	T humidifier (°C)	Measured temperature at water chamber exit

<sup>24</sup> If HAMILTON-H900 humidifier integration is enabled, and a humidifier is connected and turned on.



## Physical characteristics

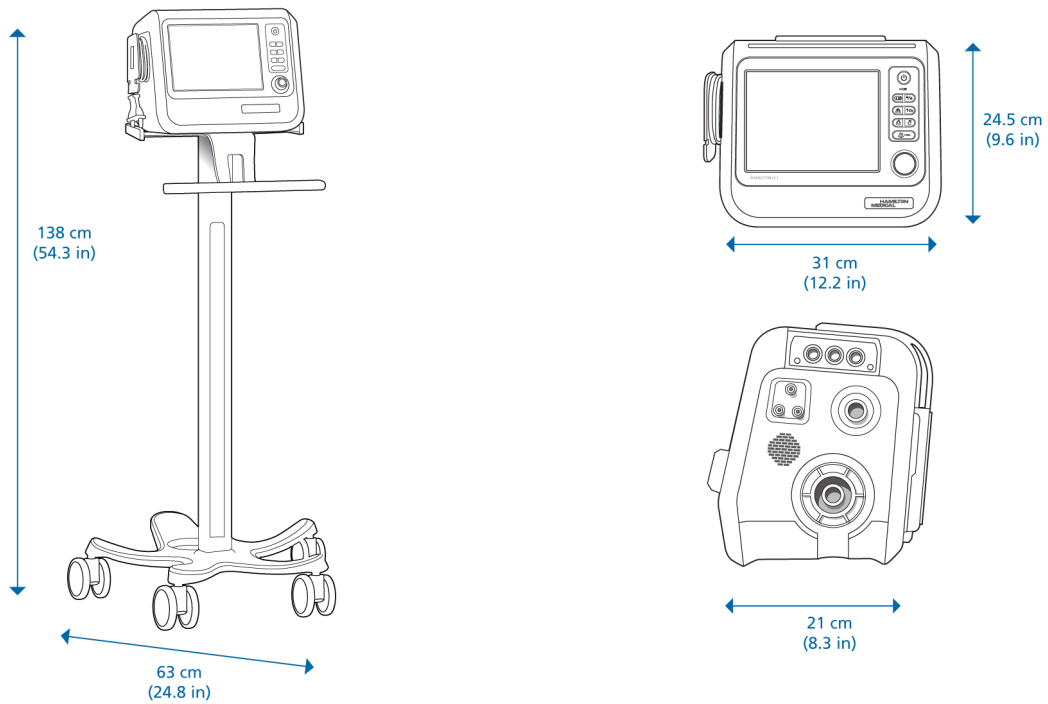

Weight	4.9 kg (10.8 lb) 16.9 kg (37.3 lb) with trolley The trolley can accommodate a maximum safe working load <sup>25</sup> of 44 kg (97 lb).
Dimensions	See graphic above
Monitor	Type: Color TFT  Size: 640 x 480 pixels, 8.4 in (214 mm) diagonal
Trolley accessories	HAMILTON-H900 mounting kit, optional O2 bottle holding system, optional tubing support arm, water bottle holder, basket

<sup>25</sup> The maximum safe working load applies to a stationary, properly load-balanced trolley.







**For devices manufactured in Switzerland**



**Manufacturer**

Hamilton Medical AG

Via Crusch 8, 7402 Bonaduz, Switzerland

+41 (0) 58 610 10 20

info@hamilton-medical.com

[www.hamilton-medical.com](http://www.hamilton-medical.com)



medin Medical Innovations GmbH

Adam-Geisler-Straße 1

DE-82140 Olching

Germany

**For devices manufactured and sold in the USA**

Printed in the USA

**Manufactured for**

Hamilton Medical AG

Via Crusch 8, 7402 Bonaduz, Switzerland

+41 (0)58 610 10 20

info@hamilton-medical.com

[www.hamilton-medical.com](http://www.hamilton-medical.com)

**Distributor in USA**

Hamilton Medical, Inc.

201 Edison Way, Unit A

Reno, NV 89502-2305, US

(800) 426-6331 (toll free), (775) 858-3200

info@hamiltonmedical.com

10103181/02

2024-02-29

Specifications are subject to change without notice. Some features are options. Not all features/products are available in all markets. For all proprietary trademarks and third-party trademarks used by Hamilton Medical AG, see [www.hamilton-medical.com/trademarks](http://www.hamilton-medical.com/trademarks).

© 2024 Hamilton Medical AG. All rights reserved.